



VELOCITY
SPEAKER DESIGN

RZA1000.4

4 Channel Amplifier

Instruction Manual

Features

- Features
- Full Range Class D
- Balanced Differential Input Stage
- Selectable Input Sensitivity
- DC Detect Remote Turn-On Mode
- Variable 12db Crossovers
- Bridgeable
- Large Gauge Speaker Output Terminals
- Full Chassis Heat Sink

Specifications

- 1,350 Watts Peak Power
- 4 x 275 Watts @ 2 Ohm RMS
- 4 x 150 Watts @ 4 Ohm RMS
- 2 x 550 Watts @ 4 Ohm RMS
- Frequency Response 20hz - 25khz
- Crossover High/Low Pass 40hz - 400hz @ 12db
- Signal Input Range .41V - 10V Balanced High & Low Level
- RCA Input - Yes
- Speaker Level Input - Yes (over RCA connection)
- Efficiency 87% @ Full Power
- Remote Trigger 12V or Signal Sense

Installation

Plan your amplifier mounting location and wire routing in the bike. You will need to secure the amplifier in a location that is not directly exposed to water. The RZA1000.4 amplifier is designed for humidity and extreme outdoor temperatures but is not designed for submersion in water. The inside structure of a Harley fairing is not waterproof. The fairing is designed to channel water away from the electronics inside the fairing. Take this into consideration when deciding on an amplifier mounting location.

Power Connections

8 Gauge cables should be used and run directly to the battery terminals. Never ground the amplifier to the frame or any other chassis ground point.

Always fuse the amplifier within 18 inches of the battery with a 60 amp fuse and a fuse holder that is designed for automotive/motorcycle conditions. The fuse holder should be easily accessible without the need for any special tools. Never place the fuse holder in an area that will not be accessible in an emergency.

Be sure that all power connections are secured in a way that will not allow them to pull or vibrate loose. Be sure that there is no exposed wire at any of the connection points.

Installation

Take care that all cables are kept away from any moving or hot parts of the bike.

Remote Input Connection

If using the remote input to trigger the amplifier, be sure that your remote circuit is properly connected to other items in the system. For example: If using a DSP the remote input of the amplifier should always be connected to the remote output circuit of the DSP and never the bike's accessory or the radio's remote output. In the event that you experience a turn-on pop after installation, and you are using a high level input first inspect your remote turn on configuration. Then you can try switching the amplifier to DC detect mode. DC detect mode will oftentimes cure turn-on pops because the amplifier will not turn on until after an audio signal is present.

Connect the Audio Input

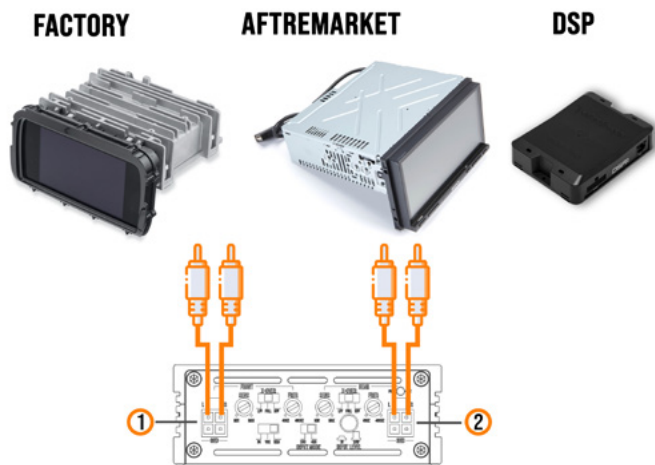

The RZA1000.4 is designed to accept any analog audio signal from an aftermarket radio, factory radio, or DSP.

If using a speaker-level signal you will need to convert your speaker type connections to an RCA type connector. We recommend one of the many solutions available from www.AmericanHardBag.com.

Always Flash Factory Radios

Whenever using a factory radio the radio should always be flashed before adding aftermarket speakers and amplifiers. For more information visit: <https://www.americanhardbag.com/pages/ultimate-harley-radio-flash-guide-for-aftermarket-speakers-and-amplifiers>

Connect the Speakers

The RZA1000.4 amplifier is designed to drive speakers as low as 2-ohm when in stereo mode or 4-ohms when in bridged 2 channel mode. Never connect a speaker or combination of speakers that sum to less than 2-ohms in stereo mode or 4-ohms in bridged mode. Never allow any of the amplifier speaker outputs to come into contact with chassis ground or to be shorted to each other.

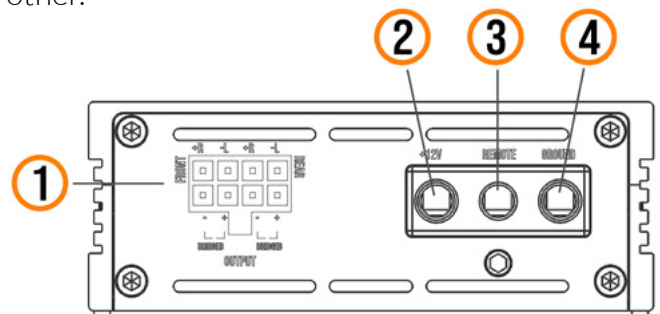

1. Speaker Output Connector
2. 12V Battery Power (60 amp)
3. Remote Trun-On Input
4. Battery Ground

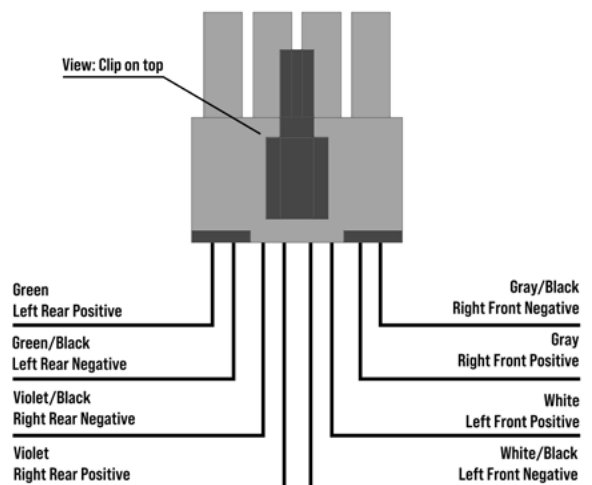

Installation

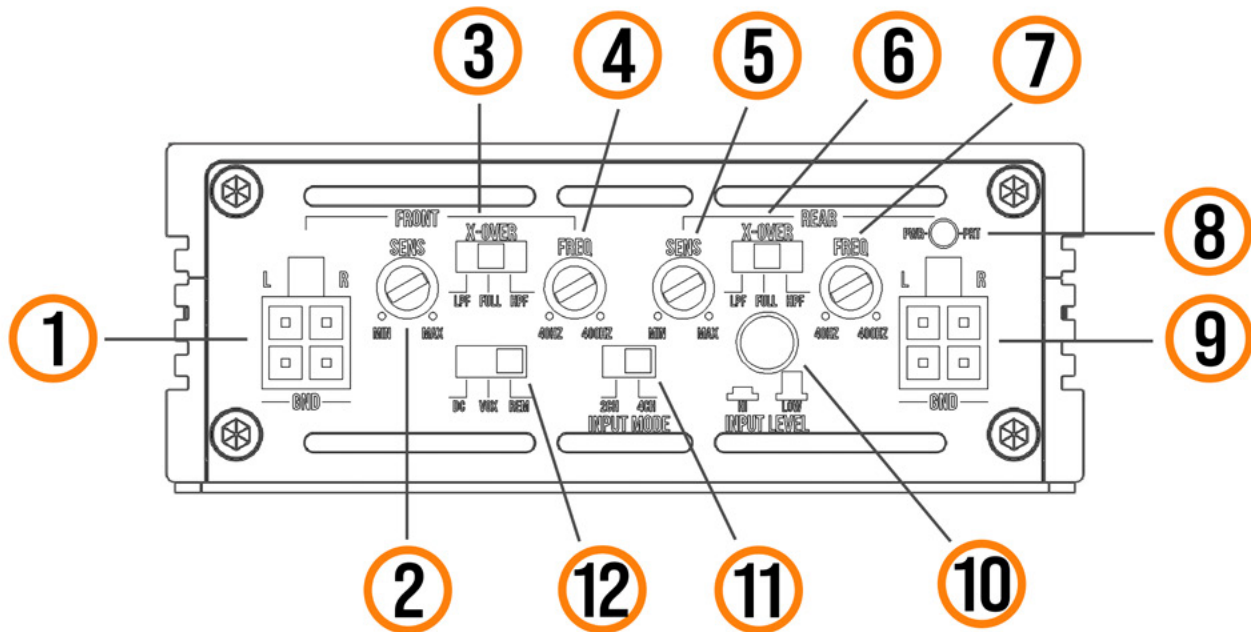

Functions

1. Front Signal Input Connector
2. Front (channels 1 & 2) Gain
3. Front Crossover. LPF = Low Pass Filter, Full = Full-range, HPF = High Pass Filter
4. Crossover Frequency Setting. 40Hz to 400Hz
5. Rear (Channels 3 & 4) Gain
6. Rear Crossover. LPF = Low Pass Filter, Full = Full-range, HPF = High Pass Filter
7. Crossover Frequency Setting. 40Hz to 400Hz
8. Power LED/Protect Indicator
9. Rear Signal Input Connector
10. Input Range Selector
11. 2 Channel/4Channel Input Selector
12. Remote Turn-On Mode Selector

Gains the Easy Way



Set your amplifier gain as shown in the video. See the full amplifier gain setup procedure here: <https://www.americanhardbag.com/pages/setting-gains-by-voltage-the-correct-way>

Installation

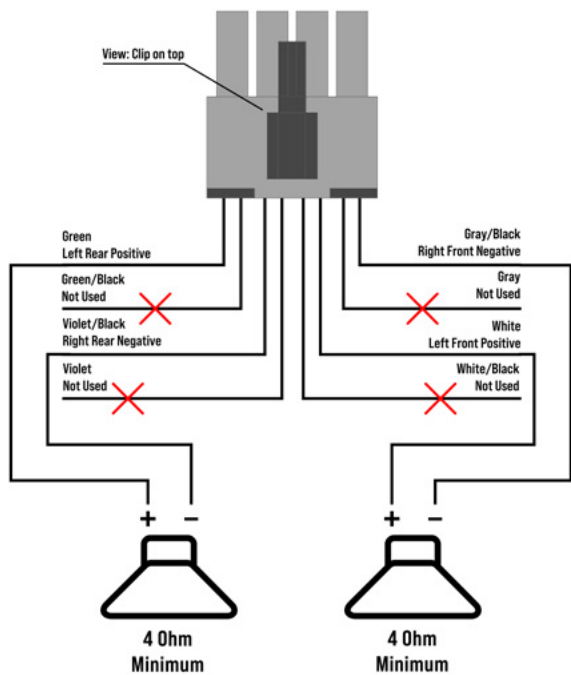

This will verify that polarity has not been accidentally flipped in a connection elsewhere on the bike. You should always do this no matter how sure you are that you have all of the connections correct.

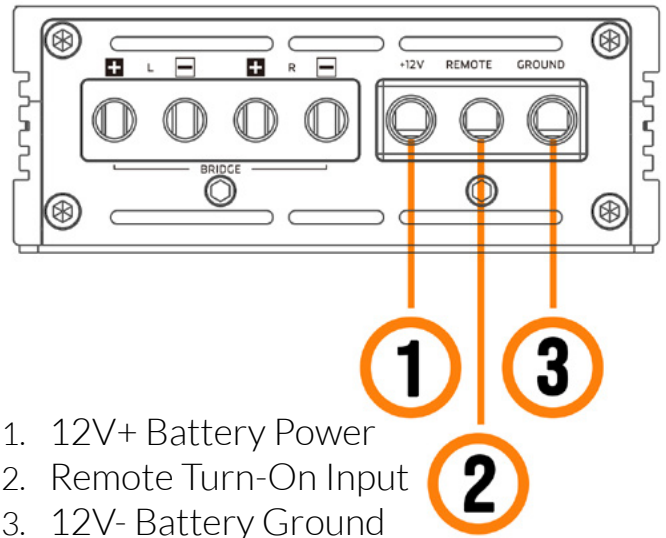

1. 12V+ Battery Power
2. Remote Turn-On Input
3. 12V- Battery Ground

Bridged 2 Channel Mode

The RZA1000.4 is capable of running in 2-channel bridged mode for extremely high-power applications. When connecting the amplifier in bridged mode only 4 of the 8 speaker connections are used. The remaining 4 unused speaker connections must be properly uninsulated so that they do not come into contact with the chassis ground or each other. Never connect the Gray, White/Black, Violet, or Green/Black speaker wires to any speaker when in bridged mode. Doing so will damage your amplifier and void the warranty.

Attention!

Always verify that speaker polarity is correct before connecting the speakers to the amplifier by using a D-cell battery to activate the speaker, perform a visual check on each speaker in the system. This should be done at the speaker lines where they make connection to the amplifier with the speaker lines disconnected from the amplifier.

Remote Input Connection

If using the remote input to trigger the amplifier, be sure that your remote circuit is properly connected to other items in the system. For example: If using a DSP the remote input of the amplifier should always be connected to the remote output circuit of the DSP and never the bike's accessory or the radio's remote output. In the event that you experience a turn-on pop after installation, and you are using a high level input first inspect your remote turn on configuration. Then you can try switching the amplifier to DC detect mode. DC detect mode will oftentimes cure turn-on pops because the amplifier will not turn on until after an audio signal is present. DC detect mode does not work with line level signal. Bikes without radios such as Road Kings should use the bike's accessory circuit to activate the amplifier's remote turn-on.

Installation

Before Making Any Settings

Connect your bike to a fully automatic car battery charger. A fully automatic battery charger will cycle on and off as needed automatically. Your battery charger needs to have at least a 10 amp capacity. 20 - 30 amps is recommended for larger systems.

- Not a battery tender
- Not an old school dummy charger
- A fully charged battery is not good enough
- Do not tune the bike while it is running

It is imperative that you are able to simulate a charge cycle while tuning your audio system. Otherwise, gains and many other settings will be invalid and your tune will change while riding the bike. This is one of the top tuning mistakes.

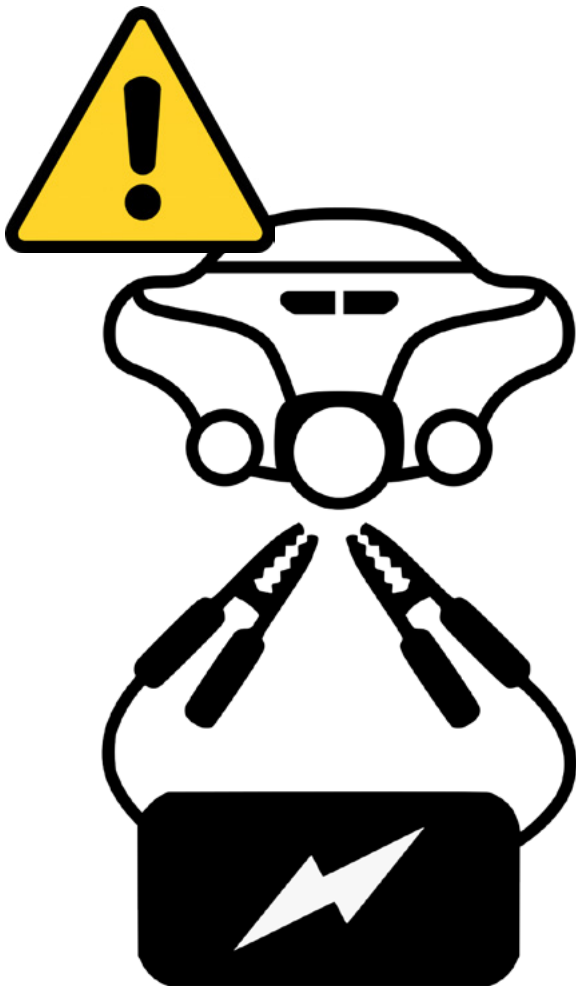

Tuning & Settings

Always make your settings in the correct order.

- 1. Turn the gains all of the way down**
- 2. Set your crossovers** to high pass if not using a DSP (digital sound processor) or to flat if you are using a DSP. If using a DSP set your crossovers in the DSP before moving forward.
- 3. Play test tracks to determine each speaker's phase**, relative to all other speakers in the system. All speakers need to be in relative phase in order for the speaker system to perform correctly. Due to delays caused by all crossovers (both passive and active) there is an 80% chance that speakers are out of phase with each other on a basic 4 channel speaker system. Systems with a great number of channels are almost certain to have one or more pairs of speakers that are out of phase. For free test tracks and more information visit: <https://www.americanhardbag.com/pages/speaker-phase>
- 4. Set equalization** for all channels if you have a DSP. If using a factory Harley radio, equalization needs to be set with the radio at 100% volume. Use the DSP master volume to reduce the signal to a level that the speakers are not playing at extreme volume levels when the radio is turned all of the way up.
- 5. Set amplifier gain.** Amplifier gain is always the last setting you make and is always set for the specific speakers you are using. Never set the amplifier gain in an attempt to reach some desired power level. EVER! The amplifier gain should be set so that the speakers reach maximum mechanical excursion at about the same time the radio reaches maximum unclipped output. Any additional gain will only generate more heat within the speakers and cause burned or melted voice coils and will result in no additional output or performance from the speakers. For a full explanation on procedure and to watch the video visit: <https://www.americanhardbag.com/pages/setting-gains-by-voltage-the-correct-way>